



\*\*\*\*\*  
\* **'WARNING'** \*  
\* It is unlawful for the user to make any replacement or substitution \*  
\* of parts, adjustments or to service the transmitter by any one \*  
\* other than a person holding a commercial 1st or 2nd class radio \*  
\* operator's license. Any change in the circuitry that would change \*  
\* or violate the technical regulations or type acceptance is \*  
\* prohibited. \*  
\*\*\*\*\*

**P.L.L. SYNTHESIZED 40 CHANNEL  
CITIZENS BAND TRANSCEIVER**

## MODEL CB-4470

This MODEL CB-4470 is fundamentally the same in circuitry design as the MODEL CB-4670 although it excludes the meter circuit and omits a part of the remote microphone unit from those of the CB-4670. In order to study what the "EQUIVALENT CIRCUIT OF IC", "HOW TO SET THE TRANSISTORS AND IC" and TROUBLE SHOOTING GUIDE are, refer to the counterparts of the MODEL CB-4670 SERVICE MANUAL.

### INDEX TO CONTENT

SPECIFICATIONS .....	2	PHASE LOCKED LOOP (P.L.L.) CIRCUIT	
PARTS LAYOUT .....	3	ALIGNMENT .....	10
GENERAL DESCRIPTION .....	4	RECEIVER ALIGNMENT .....	11
DESCRIPTION OF PHASE-LOCKED-LOOP (P.L.L.)		TRANSMITTER AND MODULATOR	
CIRCUIT		ALIGNMENT .....	11 ~ 12
What is P.L.L.? .....	4	SCHEMATIC DIAGRAM .....	13 ~ 14
Frequency Synthesizer .....	4	WIRING SIDE OF P.W. BOARD .....	15 ~ 18
Frequency Determining .....	5	TRUTH TABLE FOR A RELATIONSHIP BETWEEN	
FREQUENCY OF SYNTHESIS CHART .....	6	THE CHANNEL NUMBERS AND P.L.L. DATA OUT-	
BLOCK DIAGRAM .....	7 ~ 8	PUTS AND CHANNEL DISPLAY OUTPUTS.....	19
ALIGNMENT POINTS .....	9	SEMICONDUCTORS BASING .....	20
ALIGNMENT		REPLACEMENT PARTS LIST .....	21 ~ 26
EQUIPMENT REQUIRED .....	10		

## SHARP ELECTRONICS CORPORATION

Executive Office:

10 Keystone Place, Paramus, New Jersey 07652 (201) 265-5600

Regional Offices & Distribution Centers:

10 Keystone Place Paramus, New Jersey 07652 (201) 265-5600  
21580 Wilmington Ave., Long Beach, Calif. 90810 (213) 830-4470

U.S. Subsidiary of Sharp Corporation, Osaka, Japan

Parts Centers:

P.O. Box 664 Paramus, New Jersey 07652 (201) 265-5600  
P.O. Box 20394 Long Beach, Calif. 90801 (213) 830-4470

## SPECIFICATIONS

### Transmitter section

RF power output . . . . . 4W (maximum)  
 Frequency range . . . . . 27MHz Citizens Band  
 Channels . . . . . 40 chs. P.L.L. (Phase Locked Loop) circuit Synthesizer  
 Type of crystal . . . . . HC-18U  
     Tolerance  
     10.240MHz . . . . .  $\pm 0.003\%$   
 Transmitter modulation . . . 100% (maximum)  
 Modulation limiter . . . . . Yields high average modulation at average voice levels  
 Antenna matching . . . . . 50 ohms Un-balanced  
 Carrier deviation . . . . . Not greater than  $\pm 800\text{Hz}$  nominal on (exceeds F.C.C., requirements)  
 Harmonic suppression . . . Exceeds 60dB

### Receiver section

Audio power output . . . 3.5 Watts maximum power output  
 Sensitivity . . . . .  $0.5\mu\text{V/m}$  for 10dB S + N/N ratio at 30% at 1000Hz modulation  
 Channels . . . . . 40 chs. P.L.L. (Phase Locked Loop) circuit Synthesizer  
 Type of crystal . . . . . HC-18U  
     11.150MHz . . . . .  $\pm 0.003\%$   
 Selectivity . . . . . 6dB down at  $\pm 3\text{kHz}$ ;  
     60dB down at  $\pm 10\text{kHz}$ .  
 Intermediate frequency . . . 1st-IF: 10.695MHz,  
     2nd-IF: 455kHz  
 Circuit type . . . . . Dual conversion superheterodyne: Phase Locked Loop (P.L.L.) frequency synthesizer provides 40 transmit and receive channels.  
 Auxiliary circuits . . . . . Automatic noise limiter (ANL), Variable squelch

### General

Power source . . . . . DC 12.0V Nominal negative or positive ground  
 Antenna . . . . . 50 ohm external antenna for car or base operation

Speaker . . . . . 3-1/8"  
     P.D.S. 8-ohm Imp.  
 Semiconductor . . . . . 5-ICs  
     23-Transistors  
     29-Diodes  
     1-LED  
     2-Crystal  
 Dimensions . . . . . Main unit  
     Width : 6-11/16"  
     Height: 2-1/2"  
     Depth : 7-1/4"  
     Speaker unit  
     Width : 3-15/16"  
     Height: 3-15/16"  
     Depth : 3-1/4"  
     Microphone unit  
     Width : 2-5/8"  
     Height: 4-1/2"  
     Depth : 7/8"  
 Weight . . . . . Main unit : 3.9 lbs.  
     Speaker unit : 1.5 lbs  
     Microphone unit : 0.3 lbs.

Pocket size Remote Control Microphone Unit  
 { Microphone : Dynamic microphone (500 ohm)  
   Off-Volume control  
   Squelch control  
   Press-to-talk switch  
   Channel selection switch : UP and DOWN type  
   LED channel indicator blinking at emergency channel 9.  
   Large scale LED channel indicator : 1-ch. ~ 40-ch.

Specifications are subject to change without prior notice, within FCC rules and regulations.

## PARTS LAYOUT

### SPEAKER UNIT

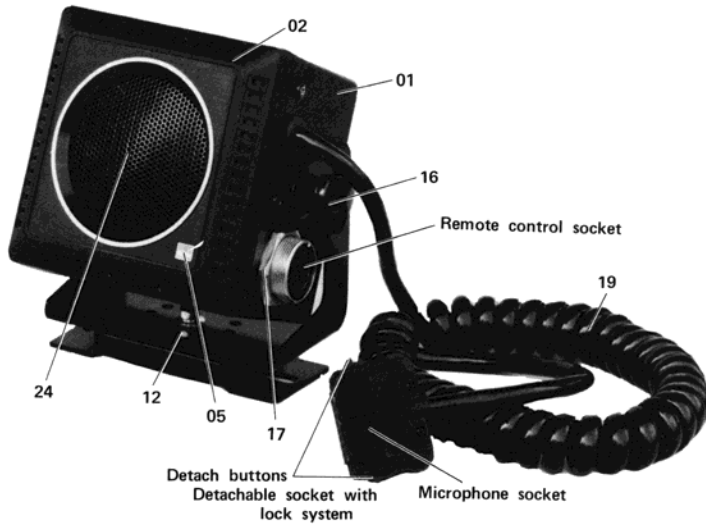

### REMOTE MICROPHONE UNIT



### MAIN UNIT (FRONT)

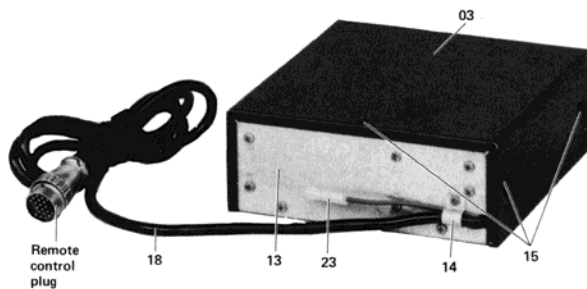

### MAIN UNIT (REAR)

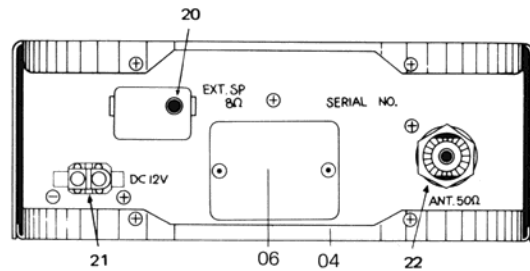

- |   |  |
|---|--|
| <ul style="list-style-type: none"> <li>① Cabinet, Speaker Side (GCABA1465AFSA)</li> <li>② Cabinet, Punching Metal Side (GCABB1465AFSA)</li> <li>③ Cabinet, Main Unit, Black (GCABA3464AFSA)</li> <li>④ Cabinet, Main Unit, Silver (GCABB3464AFSA)</li> <li>⑤ Emblem "SHARP" (HINDM1080AFSA)</li> <li>⑥ Indication Plate, Spec. (HINDM1182AFZZ)</li> <li>⑦ Cabinet, Front, Microphone Unit (HPNLH0013AAZZ)</li> <li>⑧ Cabinet, Rear, Microphone Unit (HPNLH0010AAZZ)</li> <li>⑨ Up and Down (Channel Selection Switch) Knob (JKNBZ0001AAZZ)</li> <li>⑩ Off-On Switch/Volume Control Knob (JKNBZ0002AAZZ)<br/>Squelch Control Knob (JKNBZ0002AAZZ)</li> <li>⑪ Press-to-Talk Switch Knob (JKNBZ0003AAZZ)</li> <li>⑫ Mounting Bracket Assembly, Speaker Unit (LBRC-0053AFSA)</li> </ul> | <ul style="list-style-type: none"> <li>⑬ Chassis, Front, Main Unit (LCHSS0126AFFW)</li> <li>⑭ Holder, Remote Control Cable and Memory Cord (LHLDW3057AFFW)</li> <li>⑮ Screw, Cabinet, Main Unit (LX-BZ0237AFFB)</li> <li>⑯ Moulding Screw, 5φ x 15 mm (LX-BZ0248AFZZ)</li> <li>⑰ Nut, Remote Control Socket (24φ) (LX-NZ0123AFFN)</li> <li>⑱ Remote Control Cable with Plug and Sockets Assembly (QCNW-0258AFZZ)</li> <li>⑲ Microphone Cable with Sockets Assembly (QCNW-0255AFZZ)</li> <li>⑳ Jack, External Speaker, J101 (QJAKA0052AFZZ)</li> <li>㉑ Plug, Power Supply, PG601 (QSOCZ2454AFZZ)</li> <li>㉒ Socket, Antenna (50 ohms), SO401 (QSOCZ2470AFZZ)</li> <li>㉓ Memory Cord with Socket, SO701 (QCNW-0254AFZZ)</li> <li>㉔ Punching Metal, Speaker Unit (HPNC-0109AFSA)</li> </ul> |
|---|--|

Figure 1 PARTS LAYOUT

## GENERAL DESCRIPTION (Refer to Figure 3)

### RECEIVER SECTION

An input signal sent from the antenna is applied to the 1st-mixer (transistor Q2) via the RF amplifier (transistor Q1). Meanwhile, an oscillator signal delivered from the P.L.L. synthesizer is applied to the base of the transistor Q2 (1st-mixer) via the buffer circuit (transistor Q202). In this stage the above-mentioned input signal is converted to 1st-IF signal of 10.695 MHz. This 1st-IF (10.695MHz) signal is supplied to the base of the transistor Q3 (2nd-mixer) through the transformers T3 and T4. Also to this transistor Q3 is supplied an oscillator signal (11.150MHz) from the transistor Q6, in which the signal is converted to 2nd-IF signal of 455kHz. The 2nd-IF (455 kHz) signal is amplified by the 2nd-IF amplifier (transistors Q4 and Q5) and detected by the diode D2. The output signal thus detected is applied to the terminal ⑥ of the integrated circuit IC-101 through the volume control (R925), amplified by the driver circuit and audio power amplifier circuit inside the IC-101 and finally applied to the speaker via the transformer T101.

### TRANSMITTER SECTION

An audio signal sent from the microphone is applied to the terminal ⑥ of the integrated circuit IC 101 so that it be audio-amplified and then applied to the final-stage transistor Q304 and drive-stage transistor Q303 via the transformer T101. Meanwhile, a carrier signal synthesized by the P.L.L. synthesizer circuit is amplified by the 27MHz amplifier (transistors Q301 and Q302) and applied to the final-stage transistor Q304 through the drive-stage transistor Q303, in which it is modulated together with the aforesaid audio signal and finally transmitted through the antenna.

## DESCRIPTION OF PHASE-LOCKED-LOOP (P.L.L.) CIRCUIT (Refer to Figure 2)

### 1) What is P.L.L. ?

P.L.L. is abbreviation of Phase-Locked-Loop which synchronizes with frequency and phase of the stable standard input (crystal oscillation) given from the outside, namely working not only as automatic frequency control but also as automatic phase control.

The P.L.L. is now used to realize a synthesizer. Consisting of one crystal, the synthesizer serves as an oscillator to oscillate step by step (5kHz) in the receiver section range of 16.270MHz to 16.710MHz and the transmitter section range of 16.725 MHz to 17.165MHz.

Therefore, this synthesizer can be said to be on the same level in the connection with the accuracy and stability of oscillation as the crystal oscillator.

### 2) Frequency Synthesizer

The frequencies for both transmitter and receiver are synthesized by one crystal controlled oscillator and the Phase-Locked-Loop (or P.L.L.) consisting of eight basic building blocks: the divider (1/2) IC201, the divider (1/1024) IC201, the phase detector (phase comparator) IC201, the low-pass filter IC201, the voltage controlled oscillator (or V.C.O.) IC202, the down mixer IC202, the programmable divider IC201 and the tripler T201 as shown in Figure 2.

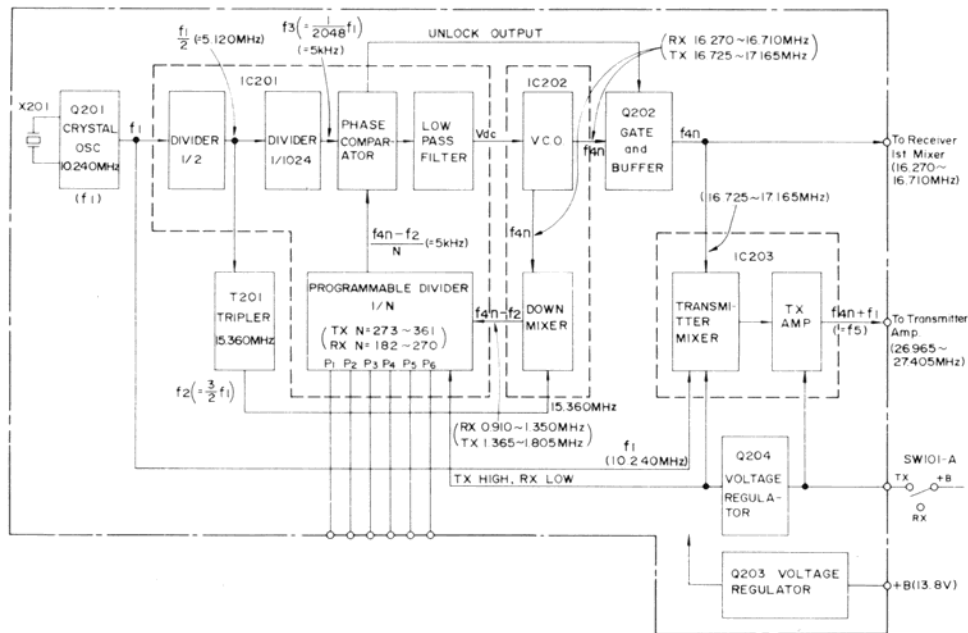

**Figure 2 P.L.L. CIRCUIT FREQUENCY SYNTHESIZER**

### 3) Frequency Determining (Refer to Figure 2 and Table 1)

- 1- The crystal oscillator consisting of a crystal X201 (10.240MHz) and transistor Q201 generates a basic frequency  $f_1$  (=10.240MHz).
- 2- The basic frequency  $f_1$  is applied to the fixed divided (1/2) network in the IC201 to be divided down to 5.120MHz signal (equivalent to 1/2 of the basic frequency  $f_1$ ). The 5.120MHz signal is further divided down to a 5kHz ( $f_3 = 1/2048 \cdot f_1$ ) signal by the fixed divided (1/1024) network and this frequency signal  $f_3$  (5kHz) is applied to the input of phase comparator.  
In addition to the above, the frequency signal  $f_1$  (10.240MHz) is also applied to the transmitter mixer inside the IC203 and the frequency signal  $f_1/2$  (5.120MHz) is converted to a signal  $f_2$  (15.360MHz) ( $f_2 = 3/2 \cdot f_1$ ) by the tripler network (transformer T201) and this frequency signal  $f_2$  is applied to the down mixer inside the IC202.
- 3- Frequency signal  $f_{4n}$  is the one that is generated by the voltage controlled oscillator (V.C.O.) inside the IC202 and this signal level is determined by DC voltage ( $V_{dc}$ ) coming from the IC201. This frequency signal  $f_{4n}$  is applied to the down mixer.  
The following will describe how the signal  $f_{4n}$  generated by the V.C.O. serves to make the P.L.L. (phase locked loop) circuit be locked.
- 4- The V.C.O. frequency signal  $f_{4n}$  is mixed down with the above-mentioned signal  $f_2$  (15.360MHz) by the down mixer inside the IC202, as a result of which there appears a mixed-down signal  $f_{4n} \cdot f_2$ . This frequency signal  $f_{4n} \cdot f_2$  is applied to the programmable divider inside the IC201.
- 5- The programmable divider (a portion of IC201) divides the frequency  $f_{4n} \cdot f_2$  by the frequency divider number  $N$  (Receiver 182 to 270, transmitter 273 to 361), which is programmable by the channel selector bit of IC901 connected to the terminal pins (11) to (16) of IC201. The assigned number is shown in Table 1. The output frequency  $(f_{4n} \cdot f_2) / N$  (near 5kHz) of the programmable divider is applied to another input of the phase comparator.
- 6- The phase comparator (IC201) compares the frequency  $f_3$  (=5kHz) and the other frequency  $(f_{4n} \cdot f_2) / N$  from the programmable divider and generates a DC voltage  $V_{dc}$  (voltage control signal) proportional to the phase differences of both frequencies. The signal  $V_{dc}$  moves downward when  $(f_{4n} \cdot f_2) / N$  goes higher than  $f_3$  and moves upward when  $(f_{4n} \cdot f_2) / N$  goes lower than  $f_3$ . When  $(f_{4n} \cdot f_2) / N$  equals to  $f_3$ , the  $V_{dc}$  does not move.  
The voltage signal  $V_{dc}$  from the output of phase comparator goes back to the V.C.O. (voltage controlled oscillator) IC202 via the low-pass filter. Then the closed feedback loop is established.
- 7- In this method, a closed-loop frequency-feedback system, which is so called P.L.L., is formed and the frequency  $f_{4n}$  of V.C.O. IC202 is locked.
- 8- When the P.L.L. is in lock, the two input signal frequencies to the phase comparator input are equal. Therefore the frequency  $f_{4n}$  is determined as follows:

#### The Receiver Frequency

$$f_{4n} = N \times f_3 + f_2$$

$$\text{where } f_2 = 15.360\text{MHz } (=3/2 \cdot f_1)$$

$$f_3 = 5\text{kHz } (=1/2048 \cdot f_1)$$

$$N = 182 \text{ to } 270 \dots \text{ Determined channel select bit of IC901 as shown in Table 1.}$$

For example, the frequency  $f_{4n}$  of "channel 1" is calculated as follows:

$$\begin{aligned} f_{4n} &= 182 \times 0.005 + 15.360 \text{ (MHz)} \\ &= 16.270 \text{ (MHz)} \end{aligned}$$

Namely " $N=182$ " is assigned for "channel 1". This frequency  $f_{4n}$  is applied to the first mixer Q2 of receiver and the mixer IC203 of transmitter through the buffer amplifier Q202 and the filter coils T205 and T206.

#### The Transmitter Frequency

$$(1) \quad f_{4n} = N \times f_3 + f_2$$

$$\text{where } f_2 = 15.360\text{MHz}$$

$$f_3 = 5\text{kHz}$$

$$N = 273 \text{ to } 361 \dots \text{ Determined by channel select bit of IC901 as shown Table 1.}$$

(During the transmission, switching signal becomes high level (DC) so that the frequency divider number  $N$  is changed from one to another and then the number will be applied to the programmable divider.)

For example, the frequency  $f_{4n}$  of "channel 1" is calculated as follows:

$$\begin{aligned} f_{4n} &= 273 \times 0.005 + 15.360 \text{ (MHz)} \\ &= 16.725 \text{ (MHz)} \end{aligned}$$

Namely " $N=273$ " is assigned for "channel 1".

This frequency  $f_{4n}$  is applied to the first mixer Q2 of receiver and the mixer IC203 of transmitter through the buffer amplifier Q202 and the filter coils T205 and T206.

- (2) The transmitter frequency  $f_5$  is determined by mixing the frequency  $f_{4n}$  and the frequency  $f_1$  (= 10.240MHz).

$$f_5 = f_{4n} + f_1$$

$$= N \times f_3 + f_2 + f_1$$

$$\text{where } f_1 = 10.240\text{MHz}$$

$$f_2 = 15.360\text{MHz}$$

$$f_3 = 5\text{kHz}$$

$$N = 273 \text{ to } 361$$

For example, the frequency  $f_s$  of "channel 1" is calculated as follows:

$$f_s = 273 \times 0.005 + 15.360 + 10.240 \text{ (MHz)}$$

$$= 26.965 \text{ (MHz)}$$

Table 1 shows the synthesized frequencies for each channel.

- 9- The gate and buffer circuit made of transistor Q202 works to prevent emission of unnecessary waves when the P.L.L. circuit is unlocked.
- 10- The frequency divider number  $N$  of programmable divider is decided by the value set by either of the channel selector LSI (IC904). In any of the channels, it is designed that the frequency divider number  $N_T$  at the transmission is larger than that  $N_R$  at the reception by a difference of 91.  
 $N_R = N_T - 91$

### FREQUENCY OF SYNTHESIS CHART

CHANNEL	$f_s$ (MHz)	$f_1$ (MHz)	$f_2 (=3/2f_1)$ (MHz)	$f_3 (=f_1/2048)$ (kHz)	RECEIVER						TRANSMITTER		
					NR	$f_{4n}$ (MHz)	$f_{4n}-f_2$ (kHz)	$f_5-f_{4n}$ (= $f_6$ ) (MHz)	$f_7$ (MHz)	$f_7-f_6$ (= $f_8$ ) (kHz)	NT	$f_{4n}$ (MHz)	$f_{4n}-f_2$ (kHz)
1	26.965	10.240	15.360	5	182	16.270	910	10.695	11.150	455	273	16.725	1365
2	26.975	10.240	15.360	5	184	16.280	920	10.695	11.150	455	275	16.735	1375
3	26.985	10.240	15.360	5	186	16.290	930	10.695	11.150	455	277	16.745	1385
4	27.005	10.240	15.360	5	190	16.310	950	10.695	11.150	455	281	16.765	1405
5	27.015	10.240	15.360	5	192	16.320	960	10.695	11.150	455	283	16.775	1415
6	27.025	10.240	15.360	5	194	16.330	970	10.695	11.150	455	285	16.785	1425
7	27.035	10.240	15.360	5	196	16.340	980	10.695	11.150	455	287	16.795	1435
8	27.055	10.240	15.360	5	200	16.360	1000	10.695	11.150	455	291	16.815	1455
9	27.065	10.240	15.360	5	202	16.370	1010	10.695	11.150	455	293	16.825	1465
10	27.075	10.240	15.360	5	204	16.380	1020	10.695	11.150	455	295	16.835	1475
11	27.085	10.240	15.360	5	206	16.390	1030	10.695	11.150	455	297	16.845	1485
12	27.105	10.240	15.360	5	210	16.410	1050	10.695	11.150	455	301	16.865	1505
13	27.115	10.240	15.360	5	212	16.420	1060	10.695	11.150	455	303	16.875	1515
14	27.125	10.240	15.360	5	214	16.430	1070	10.695	11.150	455	305	16.885	1525
15	27.135	10.240	15.360	5	216	16.440	1080	10.695	11.150	455	307	16.895	1535
16	27.155	10.240	15.360	5	220	16.460	1100	10.695	11.150	455	311	16.915	1555
17	27.165	10.240	15.360	5	222	16.470	1110	10.695	11.150	455	313	16.925	1565
18	27.175	10.240	15.360	5	224	16.480	1120	10.695	11.150	455	315	16.935	1575
19	27.185	10.240	15.360	5	226	16.490	1130	10.695	11.150	455	317	16.945	1585
20	27.205	10.240	15.360	5	230	16.510	1150	10.695	11.150	455	321	16.965	1605
21	27.215	10.240	15.360	5	232	16.520	1160	10.695	11.150	455	323	16.975	1615
22	27.225	10.240	15.360	5	234	16.530	1170	10.695	11.150	455	325	16.985	1625
23	27.255	10.240	15.360	5	240	16.560	1200	10.695	11.150	455	331	17.015	1655
24	27.235	10.240	15.360	5	236	16.540	1180	10.695	11.150	455	327	16.995	1635
25	27.245	10.240	15.360	5	238	16.550	1190	10.695	11.150	455	329	17.005	1645
26	27.265	10.240	15.360	5	242	16.570	1210	10.695	11.150	455	333	17.025	1665
27	27.275	10.240	15.360	5	244	16.580	1220	10.695	11.150	455	335	17.035	1675
28	27.285	10.240	15.360	5	246	16.590	1230	10.695	11.150	455	337	17.045	1685
29	27.295	10.240	15.360	5	248	16.600	1240	10.695	11.150	455	339	17.055	1695
30	27.305	10.240	15.360	5	250	16.610	1250	10.695	11.150	455	341	17.065	1705
31	27.315	10.240	15.360	5	252	16.620	1260	10.695	11.150	455	343	17.075	1715
32	27.325	10.240	15.360	5	254	16.630	1270	10.695	11.150	455	345	17.085	1725
33	27.335	10.240	15.360	5	256	16.640	1280	10.695	11.150	455	347	17.095	1735
34	27.345	10.240	15.360	5	258	16.650	1290	10.695	11.150	455	349	17.105	1745
35	27.355	10.240	15.360	5	260	16.660	1300	10.695	11.150	455	351	17.115	1755
36	27.365	10.240	15.360	5	262	16.670	1310	10.695	11.150	455	353	17.125	1765
37	27.375	10.240	15.360	5	264	16.680	1320	10.695	11.150	455	355	17.135	1775
38	27.385	10.240	15.360	5	266	16.690	1330	10.695	11.150	455	357	17.145	1785
39	27.395	10.240	15.360	5	268	16.700	1340	10.695	11.150	455	359	17.155	1795
40	27.405	10.240	15.360	5	270	16.710	1350	10.695	11.150	455	361	17.165	1805

#### CRYSTAL

- X1 crystal      11.150MHz =  $f_7$
- X201 crystal    10.240MHz =  $f_1$

Table 1 FREQUENCY OF SYNTHESIS CHART

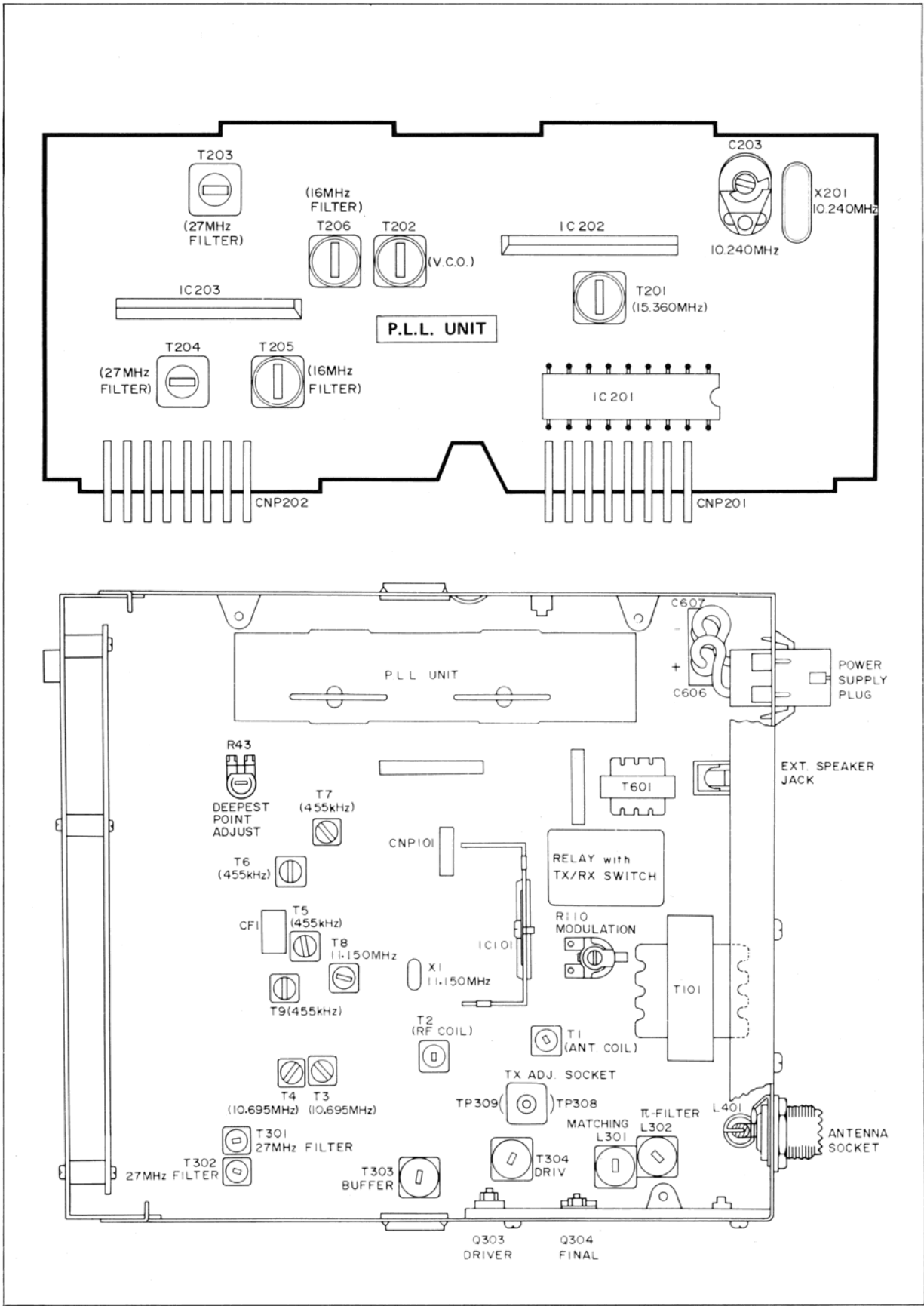

Figure 4 ALIGNMENT POINTS

## ALIGNMENT

### EQUIPMENT REQUIRED

Frequency Counter:	0 to 40MHz (High Sensitivity)	DC V.T.V.M.:	0 to 10V
Synchroscope:	0 to 50MHz	DC Milliammeter:	0 to 500mA with Low-pass Filter
Signal Generator:	10MHz to 30MHz with 1000Hz AM mod.	Dummy Load 8 ohms and 50 ohms:	Non-inductive
Audio Signal Generator:	1000Hz (sine wave)	Spectrum Analyzer or Field Strength Meter	
Audio Attenuator:	0 to 100dB	CM Coupler	
RF Output Power Meter:	0 to 5W at 27MHz	DC Power Supply:	13.8V, 2A
RF Voltmeter:	0 to 3V, 0 to 50MHz		
AC V.T.V.M.:	0 to 10V		

### [NOTE]

- 1- Keep supply voltage to 13.8V always during the alignment.
- 2- The tools to be used for the alignment should be non-metallic ones.
- 3- Be sure to keep 50 ohms dummy load connectable with the antenna terminal all the way during the transmitter alignment.
- 4- The main unit, speaker unit and microphone unit must be, when operated together, considered an independent set.

### PHASE LOCKED LOOP (P.L.L.) CIRCUIT ALIGNMENT

STEP	CONNECTION OF MEASURING INSTRUMENT	ADJUSTMENT	PROCEDURE
1 (10.240 MHz)	Connect a frequency counter, through 5PF capacitor, to the test point <b>TP201</b> (Emitter of transistor Q201).	C203	Adjust so that the frequency counter reads within 10.240 MHz $\pm$ 300 Hz.
2 (15.360 MHz)	1) Connect an RF voltmeter to the test point <b>TP202</b> (the terminal No.4 of IC202). 2) Connect a frequency counter, through 5PF capacitor, to the test point <b>TP202</b> .	T201	1) Adjust so that the RF voltmeter reads the maximum. 2) Make sure the frequency counter is reading within 15.360 MHz $\pm$ 450 Hz.
3 (V.C.O.)	Connect a D.C. V.T.V.M. to the test point <b>TP203</b> .	T202	1) Set the channel to "1". 2) Adjust so that the D.C. V.T.V.M. reads exactly 2.0V. 3) Set the channel to "1" and/or "40" and make sure the D.C. V.T.V.M. reads within 2.0V to 4.3V.
4 (16MHz Filter)	Connect an RF voltmeter to the test point <b>TP204</b> (the secondary of the transformer T205).	T205 T206	1) Set the channel to "40". 2) Adjust so that the RF voltmeter reads the maximum. (about 400mV $\pm$ 200mV)
5 (16MHz Frequency)	Connect a frequency counter, through 5PF capacitor, to the test point <b>TP204</b> (the secondary of the transformer T205).	---	1) Set the channel to "1". 2) Make sure the frequency counter is reading 16.270 MHz (RX) and 16.725 MHz (TX). 3) Set the channel to "40". 4) Make sure the frequency counter is reading 16.710 MHz (RX) and 17.165 MHz (TX).
TX	6 (27MHz Filter)	T203 T204	1) Set the channel to "20". 2) Adjust so that the RF voltmeter reads the maximum. (about 2.5V to 3.5V)
	7 (27MHz Frequency)	---	1) Set the channel to "20". 2) Make sure the frequency counter is reading within 27.205 MHz $\pm$ 300 Hz.
8 (27MHz Frequency Readjust)	Same as step 7.	C203	1) Set the channel to "20". 2) Readjust so that the frequency counter reads within 27.205 MHz $\pm$ 300 Hz.

## RECEIVER ALIGNMENT

STEP	CONNECTION OF MEASURING INSTRUMENT	ADJUSTMENT	PROCEDURE
1 (11.150 MHz)	Connect a frequency counter, through 5PF capacitor, to the test point <b>TP1</b> . (Base of transistor Q3)	T8	Adjust so that the frequency counter reads within 11.150 MHz $\pm$ 100 Hz. (The oscillation voltage then is about 90mV)
2 (1st-IF and 2nd-IF)	1) Connect an AC V.T.V.M. to both sides of the speaker voice coil lug. 2) Connect a signal generator, through 0.01 MFD capacitor, to the test point <b>TP2</b> (the secondary of the transformer T2). 3) Set the signal generator to 10.695 MHz, modulation 1000 Hz, 30% . NOTE: Be sure to connect the ground wire of signal generator to the ground of the antenna socket.	T3 T4 T5 T6 T7 T9	Adjust so that the AC V.T.V.M. reads the maximum.  IF waveform can be said to be best adjusted when it becomes maximum in size and its band width is the widest with the central frequency similar to that of the ceramic filter.
3 (RF)	1) Connect the AC V.T.V.M. to both sides of the speaker voice coil lug. 2) Connect the signal generator to the antenna socket. 3) Set the signal generator to 27.175 MHz (18 channel), modulation 1000 Hz, 30% .	T2 T1	1) Set the channel to "18". 2) Adjust the AC V.T.V.M. until it reads the maximum.
4 (Deepest Point of Squelch)	1) Connect a signal generator to the antenna socket, keeping the frequency of signal generator to 27.175 MHz ("18 channel") and modulation 1000Hz, 30%. 2) Connect a low-frequency wattmeter to the external speaker jack.	R43 (30K ohms -B)	1) Adjust the channel indication of the unit to "18" and set the volume control to "MAX" position. 2) Set the output level of a signal generator to "60 dB" (1000 Hz, 30%). At the time make sure the low-frequency wattmeter reads approx. 4W (maximum). 3) Next, adjust the volume control so that the low-frequency wattmeter indicates 500 mW. 4) Rotate the squelch control knob of the unit fully clockwise. 5) Adjust the semi-fixed resistor R43 so that the low-frequency output becomes 0.05W.

## TRANSMITTER AND MODULATOR ALIGNMENT

- 1- When the set is made ready for the transmitting operation, be sure to always connect the RF output power meter and 50 ohms dummy load to the external antenna socket—this should never be forgotten even if it is not noted down specifically. If otherwise, the final transistor Q304 may be damaged.
- 2- When making the connection of measuring instruments, see Figure 5.

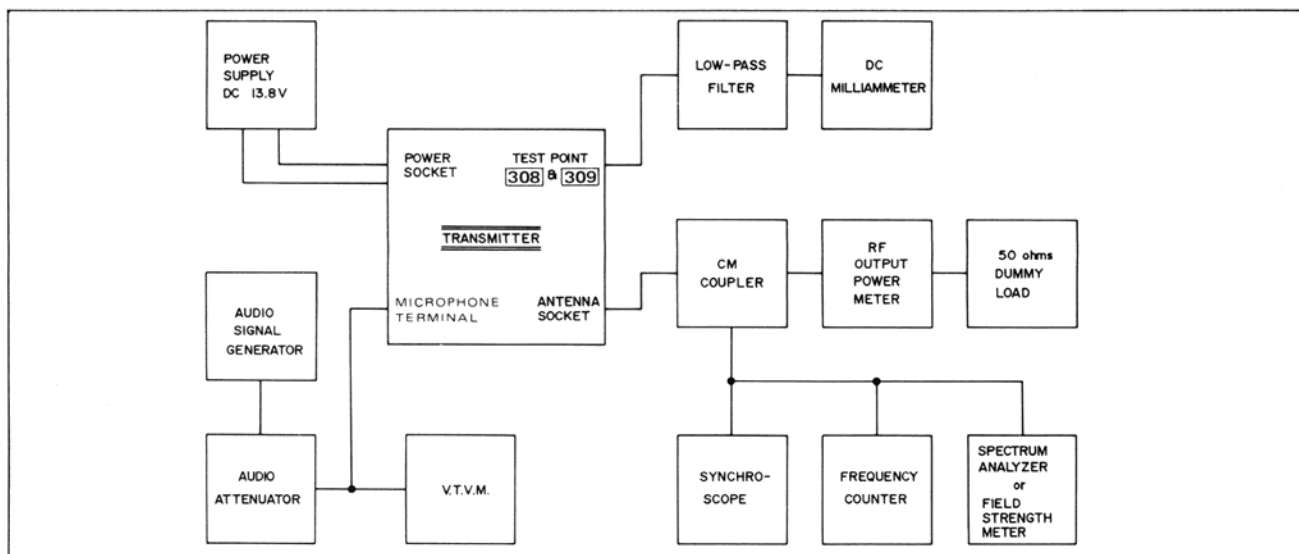

Figure 5

STEP	CONNECTION OF MEASURING INSTRUMENT	ADJUSTMENT	PROCEDURE
1 (27 MHz Filter)	Connect the synchroscope to the test point <b>TP301</b> (Base of transistor Q302).	T301 T302	1) Set the channel to "40". 2) Adjust so that the maximum waveform (amplitude) appears on the synchroscope. 3) Set the channel to "1" and/or "40" to make sure the waveform doesn't decrease in size. 4) Loosen the core of T301 by 2 turns from a peak point where the output is maximum.
2 (Buffer)	1) Remove the plug which have been inserted in the test points <b>TP308</b> and <b>TP309</b> of the set. 2) Connect in turn DC milliammeter, through the RF rejection filter shown in Figure 6, to the test points <b>TP308</b> and <b>TP309</b> .	T303	1) Set the channel to "40". 2) Adjust so that the DC milliammeter connected to the test point <b>TP309</b> reads the maximum. (Driver current)
3 (Driver)	Same as above.	T304	Adjust so that the DC milliammeter connected to the test point <b>TP309</b> indicates the dip point. The amperage then is about 45 to 80mA.
4 (Final)	Same as step 2, and connect the RF output power meter and 50 ohms dummy load to the antenna socket.	L301	Adjust so that the DC milliammeter connected to the test point <b>TP308</b> reads 450mA ± 50mA (Final current).
5 (π-Filter)	Same as above.	L302	Adjust so that the RF output power meter reads the maximum. The reading then should not exceed 4W. (FCC Rules and Regulations Part 95, Section 95. 43.)
6	Repeat the steps 2 to 5 until the best results will be obtained.		
7 (Modulation)	1) Connect the RF output power meter, 50 ohms dummy load and synchroscope, through CM coupler, to the antenna socket. 2) Connect a audio signal generator, attenuator and AC V.T.V.M. to the microphone terminal. 3) Keep the output of audio signal generator to 1000 Hz, 700mV.	R110 (1K ohms -B)	1) Set the channel to "20". 2) Turn R110 counterclockwise until the modulation limiter circuit stops its function. 3) Make sure there appears 700mV input signal at the microphone terminal from an audio signal generator. 4) Depress the press-to-talk switch on the microphone. 5) Adjust R110 so that the modulation factor of RF output waveform appeared on the synchroscope becomes 95 to 99%(See Figure 7). 6) Set the attenuator to "-41dB" (6 mV). 7) Make sure the modulation factor of RF output waveform on a synchroscope is more than 50%.

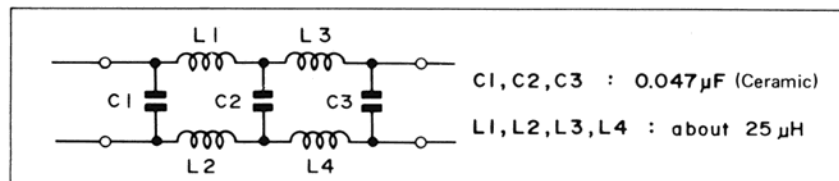

Figure 6 RF REJECTION FILTER  
(LOW-PASS FILTER)

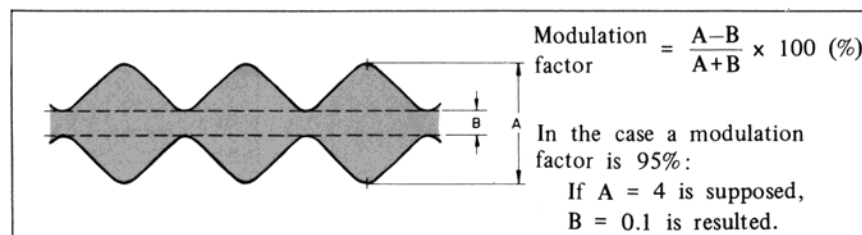

Figure 7

**TRUTH TABLE FOR A RELATIONSHIP BETWEEN THE CHANNEL NUMBERS AND P.L.L. DATA OUTPUTS AND CHANNEL DISPLAY OUTPUTS**

CHANNEL	P.L.L. DATA OUTPUT						CHANNEL DISPLAY OUTPUT											9-CH. OUT ⑦					
	P1(⑧)	P2(⑨)	P3(⑩)	P4(⑪)	P5(⑫)	P6(⑬)	⑳	㉑	㉒	㉓	㉔	㉕	㉖	㉗	㉘	㉙	㉚		㉛	㉜	㉝	㉞	㉟
	s	t	u	v	w	x	h	i	j	k	l	m	n	a	b	c	d		e	f	g		
1	0	0	0	0	0	0	1	1	1	1	1	1	1	1	0	0	0	1	1	1	1	0	
2	1	0	0	0	0	0	1	1	1	1	1	1	1	0	0	1	0	0	1	0	0	0	
3	0	1	0	0	0	0	1	1	1	1	1	1	1	0	0	0	0	1	1	0	0	0	
4	0	0	1	0	0	0	1	1	1	1	1	1	1	1	0	0	1	1	0	0	0	0	
5	1	0	1	0	0	0	1	1	1	1	1	1	1	0	1	0	0	1	0	0	0	0	
6	0	1	1	0	0	0	1	1	1	1	1	1	1	1	1	0	0	0	0	0	0	0	
7	1	1	1	0	0	0	1	1	1	1	1	1	1	0	0	0	1	1	1	1	0	0	
8	1	0	0	1	0	0	1	1	1	1	1	1	1	0	0	0	0	0	0	0	0	0	
9	0	1	0	1	0	0	1	1	1	1	1	1	1	0	0	0	1	1	0	0	1	0	
10	1	1	0	1	0	0	1	0	0	1	1	1	1	0	0	0	0	0	0	1	0	0	
11	0	0	1	1	0	0	1	0	0	1	1	1	1	1	0	0	1	1	1	1	0	0	
12	0	1	1	1	0	0	1	0	0	1	1	1	1	0	0	1	0	0	1	0	0	0	
13	1	1	1	1	0	0	1	0	0	1	1	1	1	0	0	0	0	1	1	0	0	0	
14	0	0	0	0	1	0	1	0	0	1	1	1	1	1	0	0	1	1	0	0	0	0	
15	1	0	0	0	1	0	1	0	0	1	1	1	1	0	1	0	0	1	0	0	0	0	
16	1	1	0	0	1	0	1	0	0	1	1	1	1	1	1	0	0	0	0	0	0	0	
17	0	0	1	0	1	0	1	0	0	1	1	1	1	0	0	0	1	1	1	1	0	0	
18	1	0	1	0	1	0	1	0	0	1	1	1	1	0	0	0	0	0	0	0	0	0	
19	0	1	1	0	1	0	1	0	0	1	1	1	1	0	0	0	1	1	0	0	0	0	
20	0	0	0	1	1	0	0	0	1	0	0	1	0	0	0	0	0	0	0	1	0	0	
21	1	0	0	1	1	0	0	0	1	0	0	1	0	1	0	0	1	1	1	1	0	0	
22	0	1	0	1	1	0	0	0	1	0	0	1	0	0	0	1	0	0	1	0	0	0	
23	1	0	1	1	1	0	0	0	1	0	0	1	0	0	0	0	1	1	0	0	0	0	
24	1	1	0	1	1	0	0	0	1	0	0	1	0	1	0	0	1	1	0	0	0	0	
25	0	0	1	1	1	0	0	0	1	0	0	1	0	0	1	0	0	1	0	0	0	0	
26	0	1	1	1	1	0	0	0	1	0	0	1	0	1	1	0	0	0	0	0	0	0	
27	1	1	1	1	1	0	0	0	1	0	0	1	0	0	0	0	1	1	1	1	0	0	
28	0	0	0	0	0	1	0	0	1	0	0	1	0	0	0	0	0	0	0	0	0	0	
29	1	0	0	0	0	1	0	0	1	0	0	1	0	0	0	0	1	1	0	0	0	0	
30	0	1	0	0	0	1	0	0	0	0	1	1	0	0	0	0	0	0	0	1	0	0	
31	1	1	0	0	0	1	0	0	0	0	1	1	0	1	0	0	1	1	1	1	0	0	
32	0	0	1	0	0	1	0	0	0	0	1	1	0	0	0	1	0	0	1	0	0	0	
33	1	0	1	0	0	1	0	0	0	0	1	1	0	0	0	0	0	1	1	0	0	0	
34	0	1	1	0	0	1	0	0	0	0	1	1	0	1	0	0	1	1	0	0	0	0	
35	1	1	1	0	0	1	0	0	0	0	1	1	0	0	1	0	0	1	0	0	0	0	
36	0	0	0	1	0	1	0	0	0	0	1	1	0	1	1	0	0	0	0	0	0	0	
37	1	0	0	1	0	1	0	0	0	0	1	1	0	0	0	0	1	1	1	1	0	0	
38	0	1	0	1	0	1	0	0	0	0	1	1	0	0	0	0	0	0	0	0	0	0	
39	1	1	0	1	0	1	0	0	0	0	1	1	0	0	0	0	1	1	0	0	0	0	
40	0	0	1	1	0	1	1	0	0	1	1	0	0	0	0	0	0	0	0	1	0	0	

“1” : “H” level      “0” : “L” level

Table 2

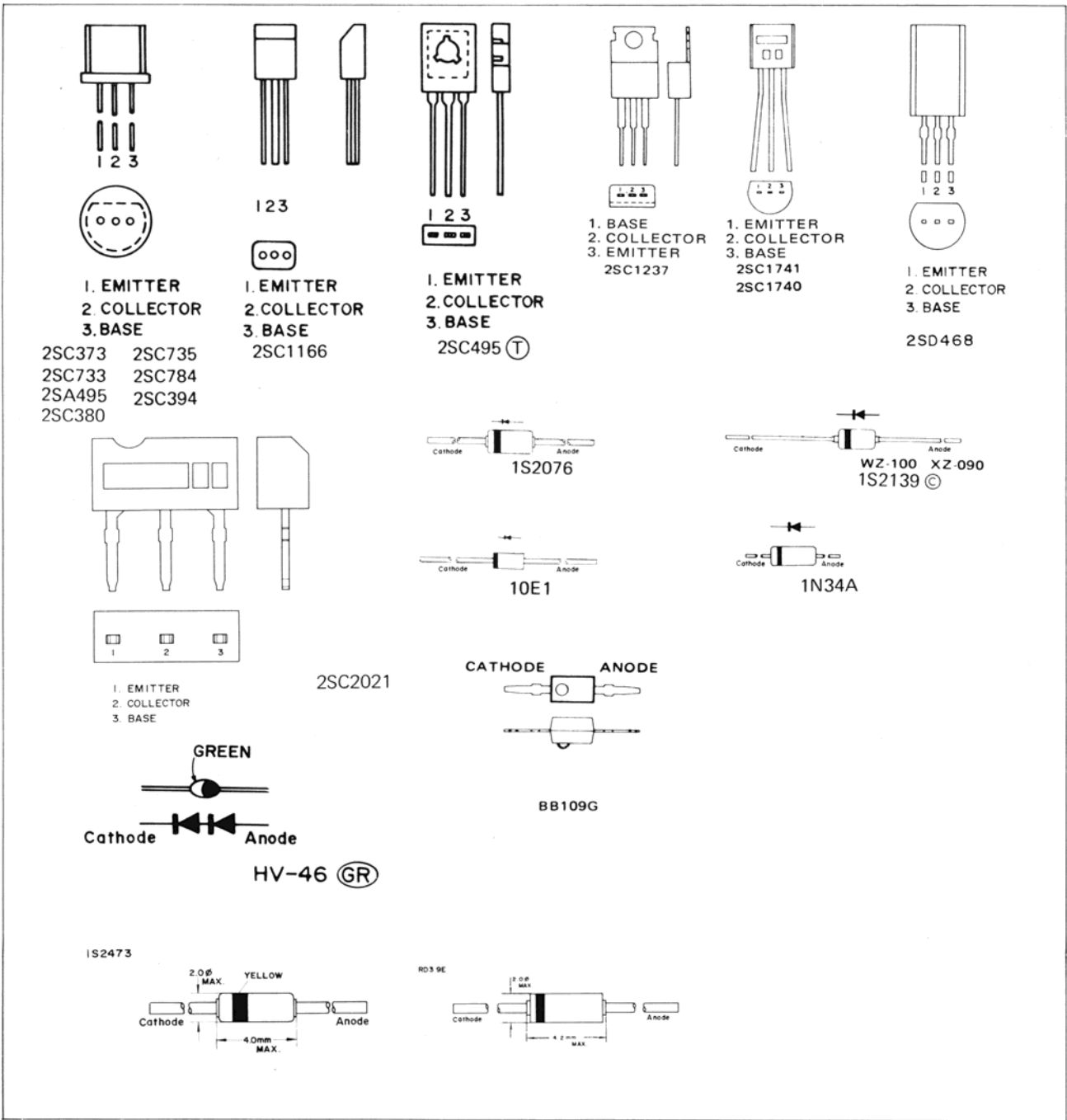

Figure 11 SEMICONDUCTORS BASING

# REPLACEMENT PARTS LIST

## "HOW TO ORDER REPLACEMENT PARTS"

To have your order filled promptly and correctly, please furnish the following informations.

1. MODEL NUMBER
2. REF. NO.
3. PART NO.
4. DESCRIPTION

Order to : Parts Center

P.O. Box 664 Paramus, New Jersey 07652 (201) 265-5600  
P.O. Box 20394 Long Beach, Calif. 90801 (213) 830-4470

REF. NO.	PART NO.	DESCRIPTION
<b>INTEGRATED CIRCUITS</b>		
IC101	RH-IX1070AFZZ	Audio Power Amplifier (TA7205AP)
IC201	RH-IX1067AFZZ	P.L.L. Synthesizer, Divider, Phase Comparator, Low-Pass Filter and Programmable Divider (TC9102P)
IC202	RH-IX1068AFZZ	P.L.L. Synthesizer, V.C.O. (Voltage Controlled Oscillator) and Down Mixer (TA7310P)
IC203	RH-IX1068AFZZ	Transmitter, 27MHz Mixer and Amplifier (TA7310P)
IC901	RH-IX0017AAZZ	C-MOS IC, Channel Selector (M58476-141P)
<b>TRANSISTORS</b>		
Q1	VS2SC784-R/1F	RF Amplifier (2SC784 <sup>®</sup> )
Q2	VS2SC394-Y/-1	1st-Mixer (10.695MHz) (2SC394 <sup>Y</sup> )
Q3	VS2SC380-O/-1	2nd-Mixer (455kHz) (2SC380 <sup>O</sup> )
Q4	VS2SC380-Y/-1	IF (455kHz) Amplifier (2SC380 <sup>Y</sup> )
Q5	VS2SC380-Y/-1	IF (455kHz) Amplifier (2SC380 <sup>Y</sup> )
Q6	VS2SC380-O/-1	Crystal (11.150MHz) Oscillator (2SC380 <sup>O</sup> )
Q7	VS2SC373-G/-1	AVC Amplifier (2SC373)
Q8	VS2SC733-BL-1	Squelch Voltage Amplifier (2SC733 <sup>BL</sup> )
Q9	VS2SC1740Q/-1	Squelch Switching (2SC1740 <sup>Q</sup> )
Q101	VS2SA495-Y/-1	Modulation Limiter (2SA495 <sup>Y</sup> )
Q201	VS2SC373-G/-1	P.L.L. Synthesizer, Crystal (10.240MHz) Oscillator (2SC373)
Q202	VS2SC373-G/-1	P.L.L. Synthesizer, Buffer and Gate (2SC373)
Q203	VS2SD468-C/-1	P.L.L. Synthesizer, Voltage Regulator (2SD468 <sup>C</sup> )
Q204	VS2SC1741/-1	P.L.L. Synthesizer, Voltage Regulator, TX (2SC1741)
Q301	VS2SC735-Y/-1	Transmitter, Buffer Amplifier (2SC735 <sup>Y</sup> )
Q302	VS2SC1166-Y-1	Transmitter, 27MHz Amplifier (2SC1166 <sup>Y</sup> )
Q303	VS2SC495-T/-1	Transmitter, Driver (2SC495 <sup>T</sup> )
Q304	VS2SC1237-1F	Transmitter, Final (2SC1237)
Q702	VS2SC1741/-1	Voltage Regulator (2SC1741)
Q703	VS2SC1741/-1	Power Switching (2SC1741)

REF. NO.	PART NO.	DESCRIPTION
Q801	VS2SD468-C/-1	Channel Indication Driver (2SD468 <sup>C</sup> )
Q802	VS2SC2021//-1	9-channel Flashing (2SC2021)
Q803	VS2SC2021//-1	9-channel Flashing (2SC2021)
<b>DIODES</b>		
D1	VHD1S2076//-1	Static Protector (1S2076)
D2	VHD1N34A///-1	AM Detector (1N34A)
D4	VHD1S2076//-1	A.N.L. (Automatic Noise Limiter) (1S2076)
D5	VHEWZ-100//1F	Zener Diode, Voltage Regulator (10V ± 0.5V) (WZ-100)
D6	VHD1S2076//-1	Squelch (1S2076)
D7	VHD1S2076//-1	Squelch (1S2076)
D8	VHD1S2473//-1	A.V.C. (1S2473)
D9	VHVHV46-G//-1	Varistor, Squelch Stabilizer (HV-46 <sup>GR</sup> )
D101	VHD1S2076//-1	Modulation Limiter (1S2076)
D102	VHD1S2076//-1	Modulation Limiter (1S2076)
D201	VHCBB109G//-1	Varicap, V.C.O. (BB109G)
D202	VHC1S2139-C-1	Varicap, TX Shifter (1S2139 <sup>C</sup> )
D204	VHEXZ-090//-1	Zener Diode, Voltage Regulator, 9V ± 0.25V (XZ-090)
D205	VHEXZ-090//-1	Zener Diode, Voltage Regulator, 9V ± 0.25V (XZ-090)
D301	VHD1S2076//-1	Static Protector (1S2076)
D302	VHD1S2076//-1	Static Protector (1S2076)
D601	VHD10E1////-1	Circuit Protector (10E1)
D602	VHD10E1////-1	Protector (10E1)
D701	VHD1S2473//-1	Squelch Switching (1S2473)
D702	VHEXZ-090//-1	Zener Diode, Voltage Regulator, 9V ± 0.25V (XZ-090)
D703	VHD10E1////-1	Protector (10E1)
D704	VHD10E1////-1	Memory (10E1)
D705	VHD10E1////-1	Memory (10E1)
D706	VHD10E1////-1	Memory (10E1)
D708	VHD10E1////-1	Memory (10E1)
D709	VHD1S2473//-1	Memory (1S2473)
D710	VHD1S2473//-1	Memory (1S2473)
D711	VHD1N34A///-1	Memory (1N34A)
D901	VHERD3.9E-B//	Zener Diode, Voltage Regulator, 3.7V ~ 4.1V (RD3.9E <sup>B</sup> )
LED901	RH-PZ0008AAZZ	LED (Light Emitting Diode), Channel Indicator (GL-7P201)
<b>COILS</b>		
L1	RCILC0023AFZZ	OSC. Choke
L101	RCILC0023AFZZ	AF Choke

# PARTS LIST

REF. NO.	PART NO.	DESCRIPTION
L301	RCILR0135AFZZ	Transmitter, Matching (Loading)
L302	RCILR0055AFZZ	Transmitter, $\pi$ -Filter
L305	RCILC0011AFZZ	RF Choke (TX)
L401	RCILR0329AFZZ	Antenna Choke

## TRANSFORMERS

T1	RCILA0412AFZZ	Antenna
T2	RCILR0304AFZZ	RF
T3	RCIL0157AFZZ	1st-IF (10.695MHz)
T4	RCIL0157AFZZ	1st-IF (10.695MHz)
T5	RCIL0228AFZZ	2nd-IF (455kHz)
T6	RCIL0229AFZZ	2nd-IF (455kHz)
T7	RCIL0169AFZZ	2nd-IF (455kHz)
T8	RCILB0421AFZZ	2nd Local Oscillator (11.150MHz)
T9	RCIL0228AFZZ	2nd-IF (455kHz)
T101	RTRNM0050AFZZ	Output and Modulation
T201	RCILR3242AAZZ	Tripler (15.360MHz)
T202	RCILB3241AAZZ	V.C.O. (Voltage Controlled Oscillator)
T203	RCILB0383AFZZ	27MHz Filter
T204	RCILB0383AFZZ	27MHz Filter
T205	RCILR3243AAZZ	16MHz Filter
T206	RCILR3243AAZZ	16MHz Filter
T301	RCILB0383AFZZ	Transmitter, 27MHz Filter
T302	RCILB0383AFZZ	Transmitter, 27MHz Filter
T303	RCILB0221AFZZ	Transmitter, Buffer
T304	RCILR0037AFZZ	Transmitter, Driver
T601	RTRNC0003AFZZ	Power Choke

## CRYSTALS

X1	RCRSB0055AFZZ	11.150MHz
X201	RCRSB0051AFZZ	10.240MHz

## CERAMIC FILTER

CF1	RFILA0056AFZZ	455kHz
-----	---------------	--------

## ELECTROLYTIC CAPACITORS

C22	VCEAAU1EW335A	3.3MFD, 25V, +75 -10%
C23	VCEAAU1EW335A	3.3MFD, 25V, +75 -10%
C26	VCAAKU0XA474M	.47MFD, 6.3V, $\pm 20\%$ , Aluminum
C30	VCEAAU1CW106Y	10MFD, 16V, +50 -10%
C31	VCEAAU1AW227Y	220MFD, 10V, +50 -10%
C37	VCEAAU1CW336Y	33MFD, 16V, +50 -10%
C39	VCAAKU0XA474M	.47MFD, 6.3V, $\pm 20\%$ , Aluminum
C107	VCEAAU1CW106Y	10MFD, 16V, +50 -10%
C108	VCEAAU1AW227Y	220MFD, 10V, +50 -10%
C109	VCEAAU1CW106Y	10MFD, 16V, +50 -10%
C112	VCEAAU1EW335A	3.3MFD, 25V, +75 -10%
C113	VCEAAU1CW336Y	33MFD, 16V, +50 -10%
C116	VCEAAU0JW476Y	47MFD, 6.3V, +50 -10%
C117	VCEAAU1CW108Y	1000MFD, 16V, +50 -10%
C119	VCEAAU1CW106Y	10MFD, 16V, +50 -10%

REF. NO.	PART NO.	DESCRIPTION
C211	VCSATU1VF224M	.22MFD, 35V, $\pm 20\%$ , Tantalu
C225	VCSATU1EF105M	1MFD, 25V, $\pm 20\%$ , Tantalu
C228	VCEAAU1AW107Y	100MFD, 10V, +50 -10%
C232	VCEAAU1AW476Y	47MFD, 10V, +50 -10%
C237	VCEAAU1HW105A	1MFD, 50V, +75 -10%
C244	VCEAAU1AW107Y	100MFD, 10V, +50 -10%
C702	VCEAAU1HW105A	1MFD, 50V, +75 -10%
C703	VCEAAU1AW108Y	1000MFD, 10V, +50 -10%
C704	VCEAAU1AW476Y	47MFD, 10V, +50 -10%
C705	VCEAAU1CW476Y	47MFD, 16V, +50 -10%
C706	VCEAAU1AW477Y	470MFD, 10V, +50 -10%
C801	VCAAKU0XA474M	.47MFD, 6.3V, $\pm 20\%$ , Aluminum
C802	VCEAAU1EW335Y	3.3MFD, 25V, +50 -10%
C803	VCEAAU1EW335Y	3.3MFD, 25V, +50 -10%
C901	VCSATU1EF105M	1MFD, 25V, $\pm 20\%$ , Tantalu
C903	VCEAAU1AW476Y	47MFD, 10V, +50 -10%

## CAPACITORS

(Unless otherwise specified capacitors are 50V, +80 -20%, Ceramic Type.)

C1	VCKZPU1HF103Z	.01MFD
C2	VCKYPU1SD103Z	.01MFD (Z5T), 30V, +80 -20%, Ceramic
C3	VCKZPU1HF103Z	.01MFD
C4	VCCSPU1HL271J	270PF, 50V, $\pm 5\%$ , Ceramic
C5	VCCSPU1HL220J	22PF, 50V, $\pm 5\%$ , Ceramic
C6	VCKYPU1HB103M	.01MFD, 50V, $\pm 20\%$ , Ceramic
C7	VCKZPU1HF103Z	.01MFD
C8	VCCSPU1HL2R0C	2PF, 50V, $\pm 0.25PF$ , Ceramic
C9	VCCSPU1HL680J	68PF, 50V, $\pm 5\%$ , Ceramic
C10	VCCSPU1HL330J	33PF, 50V, $\pm 5\%$ , Ceramic
C11	VCKYPU1HB103M	.01MFD, 50V, $\pm 20\%$ , Ceramic
C12	VCKZPU1HF103Z	.01MFD
C13	VCCSPU1HL5R0C	5PF, 50V, $\pm 0.25PF$ , Ceramic
C14	VCKZPU1HF103Z	.01MFD
C15	VCCSPU1HLR50C	0.5PF, 50V, $\pm 0.25PF$ , Ceramic
C16	VCQYKU1HM333M	.033MFD, 50V, $\pm 20\%$ , Mylar
C17	VCKZPU1HF103Z	.01MFD
C18	VCKZPU1HF103Z	.01MFD
C19	VCQYKU1HM333M	.033MFD, 50V, $\pm 20\%$ , Mylar
C20	VCQYKU1HM333M	.033MFD, 50V, $\pm 20\%$ , Mylar
C21	VCKYPU1HB472M	.0047MFD, 50V, $\pm 20\%$ , Ceramic
C24	VCQYKU1HM103M	.01MFD, 50V, $\pm 20\%$ , Mylar
C25	VCKZPU1HF223Z	.022MFD
C27	VCCSPU1HL330J	33PF, 50V, $\pm 5\%$ , Ceramic
C28	VCCSPU1HL680J	68PF, 50V, $\pm 5\%$ , Ceramic
C29	VCQYKU1HM333M	.033MFD, 50V, $\pm 20\%$ , Mylar
C32	VCCSPU1HL221J	220PF, 50V, $\pm 5\%$ , Ceramic
C33	VCCSPU1HL330J	33PF, 50V, $\pm 5\%$ , Ceramic
C34	VCCSPU1HL221J	220PF, 50V, $\pm 5\%$ , Ceramic
C35	VCKZPU1HF103Z	.01MFD
C36	VCKZPU1HF103Z	.01MFD
C38	VCKZPU1HF103Z	.01MFD
C101	VCKYPU1HB472M	.0047MFD, 50V, $\pm 20\%$ , Ceramic
C102	VCKYPU1HB472M	.0047MFD, 50V, $\pm 20\%$ , Ceramic
C103	VCQYKU1HM223M	.022MFD, 50V, $\pm 20\%$ , Mylar
C104	VCKYPU1HB222M	.0022MFD, 50V, $\pm 20\%$ , Ceramic

# PARTS LIST

REF. NO.	PART NO.	DESCRIPTION	REF. NO.	PART NO.	DESCRIPTION
C105	VCCSPU1HL271J	270PF, 50V, $\pm 5\%$ , Ceramic	C309	VCKZPU1HF103Z	.01MFD
C106	VCQYKU1HM683M	.068MFD, 50V, $\pm 20\%$ , Mylar	C310	VCCCPU1HH100F	10PF (CH), 50V, $\pm 1\%$ , Ceramic
C110	VCCSPU1HL470J	47PF, 50V, $\pm 5\%$ , Ceramic	C311	VCKZPU1HF103Z	.01MFD
C111	VCQYKU1HM104M	.1MFD, 50V, $\pm 20\%$ , Mylar	C312	VCCSPU1HL221J	220PF, 50V, $\pm 5\%$ , Ceramic
C114	VCKYPU1SD103Z	.01MFD (Z5T), 30V, +80 -20%, Ceramic	C313	VCCSPU1HL471J	470PF, 50V, $\pm 5\%$ , Ceramic
C118	VCQYKU1HM333M	.033MFD, 50V, $\pm 20\%$ , Mylar	C314	VCKYPU1SD103Z	.01MFD (Z5T), 30V, +80 -20%, Ceramic
C120	RC-KZ1010AFZZ	1000PF, 50V, +80 -20%, Ceramic (Wage Type)	C316	VCCSPU1HL180J	18PF, 50V, $\pm 5\%$ , Ceramic
C122	VCCSPU1HL680J	68PF, 50V, $\pm 5\%$ , Ceramic	C317	VCKYPU1SD103Z	.01MFD (Z5T), 30V, +80 -20%, Ceramic
C123	VCCSPU1HL680J	68PF, 50V, $\pm 5\%$ , Ceramic	C318	VCKYPU1SD103Z	.01MFD (Z5T), 30V, +80 -20%, Ceramic
C124	VCKYPU1SD103Z	.01MFD (Z5T), 30V, +80 -20%, Ceramic	C319	VCKYPU1SD103Z	.01MFD (Z5T), 30V, +80 -20%, Ceramic
C125	VCKZPU1HF103Z	.01MFD	C320	VCCSPU1HL511J	510PF, 50V, $\pm 5\%$ , Ceramic
C201	VCKYPU1SD103Z	.01MFD (Z5T), 30V, +80 -20%, Ceramic	C321	VCCSPU1HL331J	330PF, 50V, $\pm 5\%$ , Ceramic
C202	VCCCPU1HH330J	33PF (CH), 50V, $\pm 5\%$ , Ceramic	C322	VCKYPU1SD103Z	.01MFD (Z5T), 30V, +80 -20%, Ceramic
C203	RTO-H1009AFZZ	Trimmer Capacitor, 10.240MHz Oscillator	C323	VCCSPU1HL471J	470PF, 50V, $\pm 5\%$ , Ceramic
C204	VCCSPU1HL391J	390PF, 50V, $\pm 5\%$ , Ceramic	C324	VCCSPU1HL271J	270PF, 50V, $\pm 5\%$ , Ceramic
C205	VCCSPU1HL151J	150PF, 50V, $\pm 5\%$ , Ceramic	C325	VCCSPU1HL391J	390PF, 50V, $\pm 5\%$ , Ceramic
C206	VCCSPU1HL330J	33PF, 50V, $\pm 5\%$ , Ceramic	C326	VCCSPU1HL150J	15PF, 50V, $\pm 5\%$ , Ceramic
C207	VCQYKU1HM223M	.022MFD, 50V, $\pm 20\%$ , Mylar	C330	VCKYPU1SD103Z	.01MFD (Z5T), 30V, +80 -20%, Ceramic
C208	VCCCPU1HH150J	15PF (CH), 50V, $\pm 5\%$ , Ceramic	C331	VCKZPU1HF103Z	.01MFD
C209	VCCCPU1HH5R0C	5PF (CH), 50V, $\pm 0.25\%$ , Ceramic	C333	VCCSPU1HL511J	510PF, 50V, $\pm 5\%$ , Ceramic
C210	VCCSPU1HL3R0C	3PF, 50V, $\pm 0.25\%$ , Ceramic	C334	VCKZPU1HF103Z	.01MFD
C212	VCCCPU1HH470J	47PF (CH), 50V, $\pm 5\%$ , Ceramic	C335	VCCSPU1HL511J	510PF, 50V, $\pm 5\%$ , Ceramic
C213	VCCCPU1HJ100J	10PF (UJ), 50V, $\pm 5\%$ , Ceramic	C336	VCCSPU1HL330J	33PF, 50V, $\pm 5\%$ , Ceramic
C214	VCCSPU1HL101J	100PF, 50V, $\pm 5\%$ , Ceramic	C338	VCCSPU1HL101J	100PF, 50V, $\pm 5\%$ , Ceramic
C215	VCCSPU1HL101J	100PF, 50V, $\pm 5\%$ , Ceramic	C401	VCCSPU1HL151J	150PF, 50V, $\pm 5\%$ , Ceramic
C216	VCCCPU1HJ180J	18PF (UJ), 50V, $\pm 5\%$ , Ceramic	C402	VCKYPU1SD103Z	.01MFD (Z5T), 30V, +80 -20%, Ceramic
C217	VCQYKU1HM223M	.022MFD, 50V, $\pm 20\%$ , Mylar	C601	VCKZPU1HF103Z	.01MFD
C218	VCKYPU1HB102M	.001MFD, 50V, $\pm 20\%$ , Ceramic	C604	VCKZPU1HF333P	.033MFD, 50V, +100 -0%, Ceramic
C219	VCCSPU1HL101J	100PF, 50V, $\pm 5\%$ , Ceramic	C605	VCKZPU1HF333P	.033MFD, 50V, +100 -0%, Ceramic
C220	VCCSPU1HL101J	100PF, 50V, $\pm 5\%$ , Ceramic	C606, C607	RC-KZ1009AFZZ	Feed Through Capacitors with Bracket
C221	VCCSPU1HL101J	100PF, 50V, $\pm 5\%$ , Ceramic	C608	VCKZPU1HF103Z	.01MFD
C222	VCKYPU1HB102M	.001MFD, 50V, $\pm 20\%$ , Ceramic	C701	VCQYKU1HM333M	.033MFD, 50V, $\pm 20\%$ , Mylar
C223	VCQYKU1HM223M	.022MFD, 50V, $\pm 20\%$ , Mylar	C710	RC-KZ1010AFZZ	
C224	VCCSPU1HL101J	100PF, 50V, $\pm 5\%$ , Ceramic	C711	RC-KZ1010AFZZ	
C226	VCCCPU1HH330J	33PF (CH), 50V, $\pm 5\%$ , Ceramic	C712	RC-KZ1010AFZZ	
C227	VCKZPU1HF103Z	.01MFD	C715	RC-KZ1010AFZZ	
C229	VCKZPU1HF103Z	.01MFD	C717	RC-KZ1010AFZZ	
C230	VCCCPU1HH100F	10PF (CH), 50V, $\pm 1\%$ , Ceramic	C718	RC-KZ1010AFZZ	
C231	VCKZPU1HF103Z	.01MFD	C719	RC-KZ1010AFZZ	
C233	VCCRPUIHH390J	39PF (RH), 50V, $\pm 5\%$ , Ceramic	C721	RC-KZ1010AFZZ	
C234	VCKZPU1HF103Z	.01MFD	C722	RC-KZ1010AFZZ	
C235	VCCRPUIHH330J	33PF (RH), 50V, $\pm 5\%$ , Ceramic	C723	RC-KZ1010AFZZ	1000PF, 50V, +80 -20%, Ceramic (Wage Type)
C236	VCKZPU1HF103Z	.01MFD	C724	RC-KZ1010AFZZ	
C238	VCKYPU1HB102M	.001MFD, 50V, $\pm 20\%$ , Ceramic	C725	RC-KZ1010AFZZ	
C239	VCCSPU1HL820J	82PF, 50V, $\pm 5\%$ , Ceramic	C726	RC-KZ1010AFZZ	
C240	VCCSPU1HL101J	100PF, 50V, $\pm 5\%$ , Ceramic	C727	RC-KZ1010AFZZ	
C241	VCCSPU1HL101J	100PF, 50V, $\pm 5\%$ , Ceramic	C728	RC-KZ1010AFZZ	
C243	VCCSPU1HL151J	150PF, 50V, $\pm 5\%$ , Ceramic	C729	RC-KZ1010AFZZ	
C245	VCQYKU1HM103M	.01MFD, 50V, $\pm 20\%$ , Mylar	C730	RC-KZ1010AFZZ	
C301	VCCSPU1HL330J	33PF, 50V, $\pm 5\%$ , Ceramic	C731	RC-KZ1010AFZZ	
C302	VCCSPU1HL390J	39PF, 50V, $\pm 5\%$ , Ceramic	C902	VCTYPU1EX103M	.01MFD, 25V, $\pm 20\%$ , Ceramic
C303	VCCSPU1HL390J	39PF, 50V, $\pm 5\%$ , Ceramic			
C304	VCCSPU1HL3R0C	3PF, 50V, $\pm 0.25\%$ , Ceramic			
C305	VCKZPU1HF103Z	.01MFD			
C306	VCKZPU1HF103Z	.01MFD			
C307	VCCSPU1HL151J	150PF, 50V, $\pm 5\%$ , Ceramic			
C308	VCCSPU1HL4R0C	4PF, 50V, $\pm 0.25\%$ , Ceramic			

# PARTS LIST

REF. NO.	PART NO.	DESCRIPTION
<b>RESISTORS ARRAY</b>		
RM901-A ~ C	RMPTC1002AAZZ	470 ohm x 3, 1/8W
RM902-A ~ D	RMPTC1001AAZZ	470 ohm x 4, 1/8W
RM903-A ~ E	RMPTC0004AFZZ	470 ohm x 5, 1/4W
RM904-A ~ F	RMPTC1003AAZZ	1.5K ohm x 6, 1/8W

## RESISTORS

(Unless otherwise specified resistors are 1/4W,  $\pm 5\%$ , Carbon Type).

R1	VRD-ST2EE472J	4.7K ohm
R2	VRD-ST2EE152J	1.5K ohm
R3	VRD-ST2EE102J	1K ohm
R4	VRD-ST2EE222J	2.2K ohm
R5	VRD-ST2EE473J	47K ohm
R6	VRD-ST2EE562J	5.6K ohm
R7	VRD-ST2EE471J	470 ohm
R8	VRD-ST2EE472J	4.7K ohm
R9	VRD-ST2EE333J	33K ohm
R10	VRD-ST2EE681J	680 ohm
R12	VRD-SU2EY223J	22K ohm
R13	VRD-ST2EE472J	4.7K ohm
R14	VRD-ST2EE102J	1K ohm
R15	VRD-ST2EE273J	27K ohm
R16	VRD-SU2EY562J	5.6K ohm
R17	VRD-SU2EY102J	1K ohm
R18	VRD-SU2EY102J	1K ohm
R20	VRD-SU2EY224J	220K ohm
R21	VRD-SU2EY333J	33K ohm
R22	VRD-SU2EY223J	22K ohm
R23	VRD-ST2EE333J	33K ohm
R24	VRD-ST2EE153J	15K ohm
R27	VRD-SU2EY104J	100K ohm
R28	VRD-SU2EY683J	68K ohm
R29	VRD-SU2EY104J	100K ohm
R30	VRD-SU2BY333J	33K ohm, 1/8W, $\pm 5\%$ , Carbon
R31	VRD-SU2EY154J	150K ohm
R34	VRD-ST2EE222J	2.2K ohm
R35	VRD-SU2EY222J	2.2K ohm
R36	VRD-ST2EE223J	22K ohm
R37	VRD-ST2EE472J	4.7K ohm
R38	VRD-ST2EE151J	150 ohm
R39	VRD-ST2EE101J	100 ohm
R40	VRD-SU2EY823J	82K ohm
R41	VRD-ST2EE471J	470 ohm
R42	VRD-ST2EE563J	56K ohm
R43	RVR-M0146AFZZ	30K (B) ohm, Deepest Point Adjust
R44	VRD-SU2EY683J	68K ohm
R45	VRD-SU2EY682J	6.8K ohm
R102	VRD-ST2EE222J	2.2K ohm
R103	VRD-ST2EE470J	47 ohm
R106	VRD-ST2EE222J	2.2K ohm
R107	VRD-ST2EE222J	2.2K ohm
R108	VRD-ST2EE223J	22K ohm
R109	VRD-ST2EE153J	15K ohm
R110	RVR-M0123AFZZ	1K (B) ohm, Modulation Level Adjust
R112	VRD-SU2EY563J	56K ohm

REF. NO.	PART NO.	DESCRIPTION
R140	VRD-ST2HA1R0K	1 ohm, 1/2W, $\pm 10\%$ , Carbon
R201	VRD-SS2EY563J	56K ohm
R202	VRD-SS2EY473J	47K ohm
R203	VRD-SS2EY152J	1.5K ohm
R205	VRD-SS2EY222J	2.2K ohm
R206	VRD-SS2EY103J	10K ohm
R207	VRD-SS2EY562J	5.6K ohm
R208	VRD-SS2EY103J	10K ohm
R209	VRD-SS2EY224J	220K ohm
R210	VRD-SS2EY103J	10K ohm
R211	VRD-SS2EY102J	1K ohm
R212	VRD-SS2EY103J	10K ohm
R214	VRD-SS2EY561J	560 ohm
R215	VRD-SS2EY222J	2.2K ohm
R216	VRD-SS2EY331J	330 ohm
R217	VRD-SS2EY683J	68K ohm
R219	VRD-SS2EY560J	56 ohm
R220	VRD-SS2EY471J	470 ohm
R221	VRD-SS2EY183J	18K ohm
R222	VRD-SS2EY333J	33K ohm
R223	VRD-SS2EY102J	1K ohm
R224	VRD-SS2EY680J	68 ohm
R225	VRD-SS2EY561J	560 ohm
R226	VRD-SS2EY471J	470 ohm
R227	VRD-SS2EY560J	56 ohm
R228	VRD-SS2EY222J	2.2K ohm
R229	VRD-SS2EY222J	2.2K ohm
R301	VRD-ST2EE123J	12K ohm
R302	VRD-ST2EE222J	2.2K ohm
R303	VRD-ST2EE221J	220 ohm
R304	VRD-ST2EE223J	22K ohm
R305	VRD-ST2EE470J	47 ohm
R306	VRD-ST2EE332J	3.3K ohm
R307	VRD-ST2EE101J	100 ohm
R308	VRD-ST2EE101J	100 ohm
R309	VRD-ST2EE680J	68 ohm
R310	VRD-ST2HA220J	22 ohm, 1/2W, $\pm 5\%$ , Carbon
R312	VRD-ST2HA471J	470 ohm, 1/2W, $\pm 5\%$ , Carbon
R313	VRD-ST2EE332J	3.3K ohm
R516	VRD-ST2HA101K	100 ohm, 1/2W, $\pm 10\%$ , Carbon
R517	VRD-ST2HA681K	680 ohm, 1/2W, $\pm 10\%$ , Carbon
R518	VRS-PT3DB221K	220 ohm, 2W, $\pm 10\%$ , Oxide Film
R702	VRD-ST2EE102J	1K ohm
R706	VRD-ST2EE104J	100K ohm
R707	VRD-ST2EE104J	100K ohm
R710	VRD-ST2EE101J	100 ohm
R711	VRD-ST2EE471J	470 ohm
R712	VRD-ST2EE472J	4.7K ohm
R713	VRD-ST2EE331J	330 ohm
R801	VRS-PT3DB470K	47 ohm, 2W, $\pm 10\%$ , Oxide Film
R802	VRD-ST2EY102J	1K ohm
R803	VRD-ST2EY104J	100K ohm
R804	VRD-ST2EY102J	1K ohm
R805	VRD-ST2EY331J	330 ohm
R806	VRD-ST2EY104J	100K ohm
R901	VRD-SC2EF471J	470 ohm
R902	VRD-SU2EF471J	470 ohm
R921	VRD-SU2EF474J	470K ohm
R923	VRD-SC2EF561J	560 ohm
R924	RVR-C0001AAZZ	5K (C) ohm, Squelch Control
R925/ SW903	RVR-B0006AAZZ	5K (B) ohm, Volume Control with OFF-ON Switch

# PARTS LIST

REF. NO.	PART NO.	DESCRIPTION	REF. NO.	PART NO.	DESCRIPTION
<b>MISCELLANEOUS</b>					
01	GCABA1465AFSA	Cabinet, Speaker Side		PGUMS0110AF00	Cushion, P.L.L. Unit, Rubber
02	GCABB1465AFSA	Cabinet, Punching Metal Side		PHAG-001MAFFC	Microphone Hanger, Small
03	GCABA3464AFSA	Cabinet, Main Unit		PHAG-002MAFFN	Microphone Hanger, Large
04	GCABB3464AFFW	Cabinet, Main Unit	} See Figure 1	PRDAR0144AFFW	Heat Sink, Transistors (Q303 and Q304)
05	HINDM1080AFSB	Emblem "SHARP", Cabinet of Punching Metal Side		PRDAR0145AFFW	Heat Sink, Integrated Circuit IC101
06	HINDM1182AFZZ	Indication Plate, Spec.		PSLDM3136AFFW	Shield Plate, Wage Type Ceramic Capacitors, Remote P.C. Board
24	HPNC-0109AFSA	Punching Metal, Speaker Unit		PSPO-0059AFZZ	Sponge, Speaker Unit P.C. Board
07	HPNLH0013AAZZ	Cabinet, Front, Microphone Unit			
08	HPNLH0010AAZZ	Cabinet, Rear, Microphone Unit	CNP101, CNP102, CNP103, CNP104, CNS702, CNS704		Connecting Cord with Sockets (10-Pin, 14-Pin) and Plugs (7-Pin, 10-Pin x 2, 5-Pin) Assembly
09	JKNBZ0001AAZZ	Knob, Up and Down (Channel Selection Switch)		QCNCM0902AGZZ	Plug, 9-Pin
10	JKNBZ0002AAZZ	Knob, Off-On Switch/Volume Control, Squelch Control		CNP702	Plug, 9-Pin
11	JKNBZ0003AAZZ	Knob, Press-to-Talk Switch		CNP703	Plug, 11-Pin
	LANGF0407AFFW	Metal Plate, Output/Modulation Transformer, Small (Flat)		CNP704	Plug, 13-Pin
	LANGQ0545AFFW	Fixing Metal, Remote P.C. Board		CNP705	Plug, 1-Pin
	LANGR0418AFFW	Fixing Metal, Output/Modulation Transformer, Large		CNP801	Plug, 2-Pin, Speaker
	LANGT0650AFFW	Bracket, Cabinet of Punching Metal Side		CNP803	Plug, 14-Pin
	LANGT0651AFFW	Mounting Bracket, Main Unit		CNS701, CNS703, PG801/18	Remote Control Cable with Plug (PG801) and Sockets Assembly
	LANGT0663AFZZ	Fixing Metal, Punching Metal		CNS801	Connecting Cord with Socket, Speaker
12	LBRC-0053AFSA	Mounting Bracket Assembly, Speaker Unit		QCNCM1101AGZZ	Plug, 11-Pin
	LBSHZ0051AFZZ	Bushing, Transistor Q304		QCNCM1301AGZZ	Plug, 13-Pin
	LCHSM0264AFFW	Chassis, Main Unit		QCNTZ0071AFZZ	Plug, 1-Pin
	LCHSM0279AFFW	Chassis, Speaker Unit		CNP801	Plug, 2-Pin, Speaker
	LCHSM2082AAZZ	Bracket, P.L.L. Circuit P.C. Board		CNP803	Plug, 14-Pin
13	LCHSS0126AFFW	Chassis, Front, Main Unit		CNS701, CNS703, PG801/18	Remote Control Cable with Plug (PG801) and Sockets Assembly
	LHLDW3009AFFW	Holder, Microphone Cable		QCNCM1401AGZZ	Plug, 14-Pin
14	LHLDW3057AFFW	Holder, Remote Control Cable and Memory Cord		CNS701, CNS703, PG801/18	Remote Control Cable with Plug (PG801) and Sockets Assembly
15	LX-BZ0237AFFB	Screw, Cabinet, Main Unit		QCNCM095BAFZZ	Plug, 2-Pin, Speaker
16	LX-BZ0248AFZZ	Moulding Screw, 5φ x 15mm		CNP803	Plug, 14-Pin
	LX-LZ0001AGZZ	Rivet, Indication Plate of Spec.		CNS701, CNS703, PG801/18	Remote Control Cable with Plug (PG801) and Sockets Assembly
	LX-LZ0051AF00	Push Rivet, Nylon, Speaker Unit		QCNCM1401AGZZ	Plug, 14-Pin
17	LX-NZ0123AFFN	Nut, Remote Control Socket (24φ)		CNS701, CNS703, PG801/18	Remote Control Cable with Plug (PG801) and Sockets Assembly
	LX-TZ0001AFFE	Self-Tapping Screw (5φ), Mounting Bracket of Main Unit		QCNCM1101AGZZ	Plug, 11-Pin
	LX-WZ3017CEFN	Shakeproof Lockwasher External Type, Main P.C. Board		QCNCM1301AGZZ	Plug, 13-Pin
	LX-WZ3057AFFN	Washer, Remote Control Socket (24φ)		QCNTZ0071AFZZ	Plug, 1-Pin
	LX-WZ9055AFZZ	Washer (φ6.5), Speaker Unit, Plastic		CNP801	Plug, 2-Pin, Speaker
	PCOVS1002AAZZ	Cover, P.L.L. Circuit P.C. Board		CNP803	Plug, 14-Pin
	PFLT-0326AF00	Felt, Cabinet of Punching Metal Side, 90mm x 90mm		CNS701, CNS703, PG801/18	Remote Control Cable with Plug (PG801) and Sockets Assembly
	PFLT-0338AF00	Felt, Cabinet of Punching Metal Side, 34mm x 5mm		QCNCM1401AGZZ	Plug, 14-Pin
	PFILW0005AFZZ	Film, Channel Indicator LED901, Red		CNS701, CNS703, PG801/18	Remote Control Cable with Plug (PG801) and Sockets Assembly
				QFS-D201AAGNA	Fuse, 200mA
				QFS-A232AAFNA	Fuse, 2.3A
				QFSHJ9052AFZZ	Power Supply Cord with Fuse Holder and Socket
				QFSHJ9054AFZZ	Memory Cord (Power Supply) with Fuse Holder and Plug
			J101/20	QJAKA0052AFZZ	Jack, External Speaker
				QPWBE0061AAZZ	Printed Circuit Board, Remote Microphone Circuit
				QPWBF0052AAZZ	Printed Circuit Board, P.L.L. Circuit
				QPWBF0612AFZZ	Printed Circuit Board, Main Circuit
				QPWBF0675AFZZ	Printed Circuit Board, Remote Unit
				QPWBF0676AFZZ	Printed Circuit Board, Speaker Unit
			PG201	QPLGZ0850AFZZ	Plug, 8-Pin
			PG202	QPLGZ0850AFZZ	Plug, 8-Pin
			PG601/21	QSOCZ2454AFZZ	Plug, Power Supply
			PG901	QCNTZ0001AAZZ	Plug, 20-Pin, Microphone Unit
				QSOCE0401AFZZ	Socket, Test Point TP308 and TP309
				QPLGE0403AGZZ	Plug, Test Point TP308 and TP309
			SO401/22	QSOCZ2470AFZZ	Socket, Antenna (50 ohms)

# PARTS LIST

REF. NO.	PART NO.	DESCRIPTION	REF. NO.	PART NO.	DESCRIPTION
SO701/23	QCNW-0254AFZZ	Memory Cord with Socket		RTUNS0052AFZZ	P.L.L. Synthesizer Unit
SW101-A	RRLYZ0007AFZZ	Relay with Receiver/Transmitter Switch		SPAKA0488AFZZ	Packing Add.
~D/ RLY601				SPAKC1061AFZZ	Packing Case
SW701, RLY701	RRLYZ0009AGZZ	Relay with Power Switch		SPAKX0162AFZZ	Packing Add., Cushion
SW901	QSW-P0002AAZZ	Switch, Up (Channel Selection)		SSAKH0016AGZZ	Polyethylene Bag, Main Unit
SW902	QSW-P0002AAZZ	Switch, Down (Channel Selection)		SSAKH0070AGZZ	Polyethylene Bag, Remote Control Microphone Unit
SW903/ R925	RVR-B0006AAZZ	Switch, OFF-ON with Volume Control (5K-B ohm)		SSAKH0113AGZZ	Polyethylene Bag, Speaker Unit
SW904	QSW-P0003AAZZ	Switch, Press-to-Talk (P.T.T.)	SP801	TINSE0529AFZZ	Operation Manual
	RMICD0001AAZZ	Dynamic Microphone, 500 ohms (at 1kHz)		VSP0080P-288A	Speaker, 8 ohms, 8cm
	RMICB0051AFZZ	Remote Control Microphone Unit		XCBCS30P10000	Screw, Mounting Bracket of Speaker Unit
				XCPSN30P12000	Tapping Screw (3φ x 12mm), Microphone Unit
				XWHGZ28-20100	Rubber Washer, Main P.C. Board